



The taste experts

GOURMET WATER FOR CATERING AND VENDING MACHINES

BWT bestmax PREMIUM is a filter system with which you can refine raw water to produce gourmet water that is outstandingly suited to making hot beverages such as coffee, espresso and tea. The modular multistage filter uses patented BWT Magnesium Technology, which also mineralizes the filtrate with magnesium. This flavour carrier guarantees high sensory quality in both the water and the products made from it. The filter system consists of a filter cartridge with a BWT besthead filter head (see graphic) that is screwed on. The bypass (0-3) is set on the filter head depending on the water hardness and requirement. Check valves in the filter head prevent backflow and uncontrolled water discharge. BWT bestmax PREMIUM food-safe filter systems are pressureresistant and safe. They can be used worldwide in any drinking water system.

BWT BESTHEAD FILTER HEAD

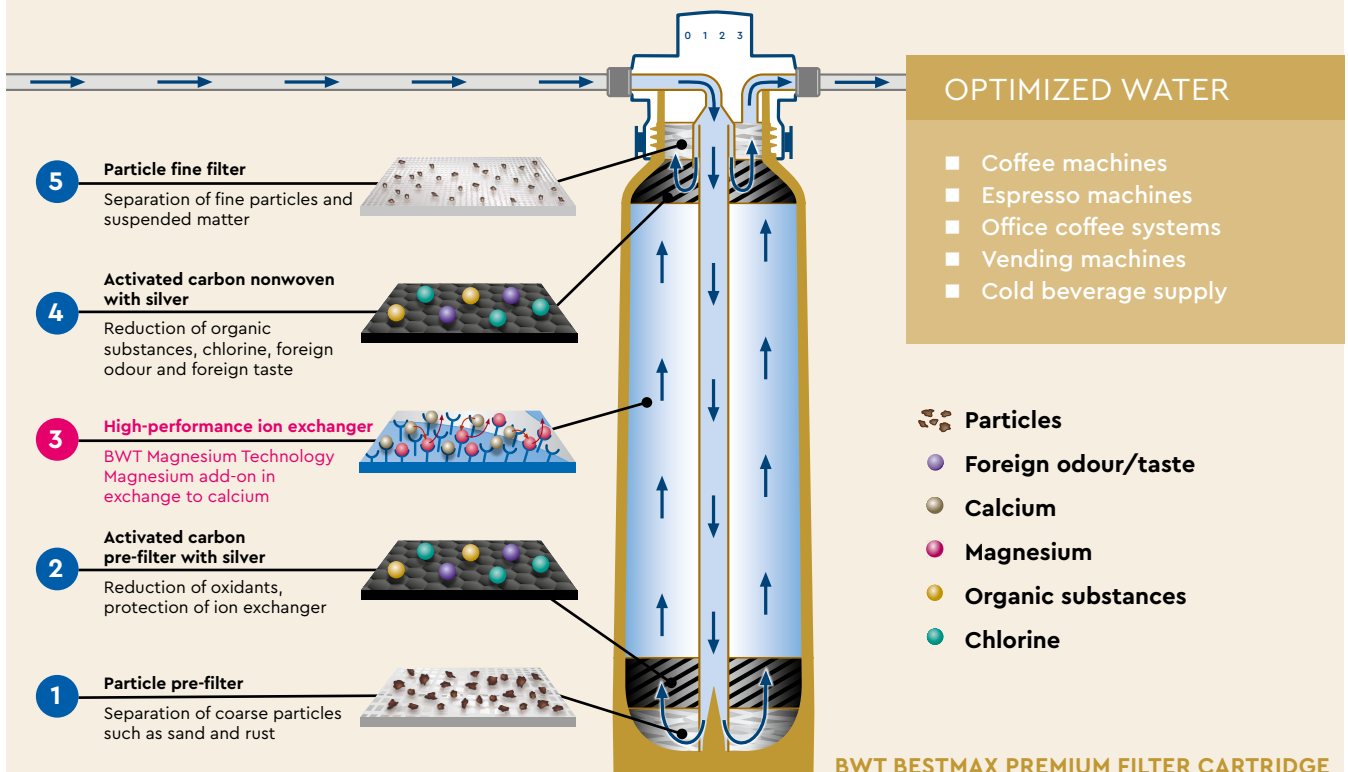

TECHNICAL DATA

Size	S	V	M	XL	2XL
Total height without bracket (A) in mm	368	429	485	512	576
Connection height (B) in mm	307	368	424	451	515
Ø filter cartridge (C) in mm	88	110	130	147	185
Weight in kg (dry/wet)	0.9/1.5	2.1/3.2	2.8/4.2	3.8/6.0	7.5/11.0
Order no. for filter cartridge	FS22P00A00	FS23P00A00	FS24P00A00	FS28P00A00	FS30P00A00

SETTINGS AND CAPACITIES/L⁽¹⁾

Vending, without steam generation						
Total hardness	Bypass	Size				
		S	V	M	XL	2XL
≤7	3	≥ 1285	≥ 3085	≥ 4625	≥ 7370	≥ 12000
8	3	1125	2700	4050	6450	10500
10	3	900	2160	3240	5160	8400
12	3	680	1630	2450	3900	6350
14	3	580	1400	2100	3340	5440
17	3	430	1035	1550	2470	4025
20	3	365	880	1320	2100	3420
23	3	315	765	1145	1825	2975
≥ 25	2	≤ 290	≤ 700	≤ 1055	≤ 1680	≤ 2735

Hot beverage preparation with steam generation						
Total hardness	Bypass	Size				
		S	V	M	XL	2XL
≤7	3	≥ 1070	≥ 2570	≥ 3855	≥ 6140	≥ 10000
8	3	935	2250	3375	5375	8750
10	3	750	1800	2700	4300	7000
12	2	565	1360	2040	3250	5290
14	2	485	1165	1750	2785	4535
17	1	355	860	1290	2060	3355
20	1	305	730	1100	1750	2850
23	1	265	635	955	1520	2480
≥ 25	1	≤ 240	≤ 585	≤ 880	≤ 1400	≤ 2280

⁽¹⁾ Capacities may deviate by up to ±5 % depending on the local water quality and volume flow. Subject to change.

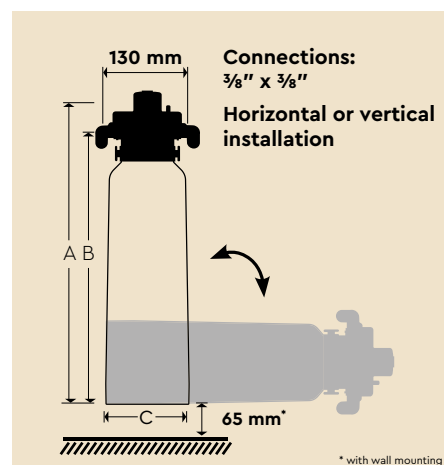

OPERATING CONDITIONS

Input pressure: 2–8 bar
 Water temperature: 4–30 °C
 Ambient temperature: 4–40 °C

ACCESSORIES

	Description	Order number
BWT besthead FLEX filter head	BWT besthead FLEX with 2 connectors 90° elbow, FLEX Insert, M 3/8" made from GFP	FS00Z20A00
BWT besthead FLEX Set 1	BWT besthead FLEX with 2 connectors 90° elbow, FLEX Insert, M 3/8" made from GFP, Connection hose DN 8, 1.5 m, with ball valve, FLEX Insert 90° elbow made from GFP, cap nut FM 3/8", Connector straight, FLEX Insert × M 3/8" made from GFP, Reduction FM 3/4" × M 3/8" made from GFP	FS00Z39A00



MANUFACTURER:

BWT Holding GmbH:
 Walter-Simmer-Str. 4
 5310 Mondsee, Austria
BWT-WAM.COM

SALES:

BWT water+more
 Deutschland GmbH:
info@water-and-more.de
 Tel.: +49 611 58019-0

